

PRODUCT SPECIFICATIONS

- PHYSICAL DATA
- EXTERNAL DIMENSIONS
- BLOCK DIAGRAM
- ABSOLUTE MAXIMUM RATINGS
- ELECTRICAL CHARACTERISTICS
- TIMING DIAGRAMS
- OPERATING PRINCIPLES & METHODS
- DISPLAY DATA PATTERN
- FL BACKLIGHT CHARACTERISTICS
- ELECTRO-OPTICAL CHARACTERISTICS
- INTERFACE PIN CONNECTIONS
- PART LIST
- RELIABILITY
- QUALITY GUARANTEE
- INSPECTION CRITERIA
- PRECAUTIONS FOR USING LCD MODULES
- USING LCD MODULES

■ BLOCK DIAGRAM

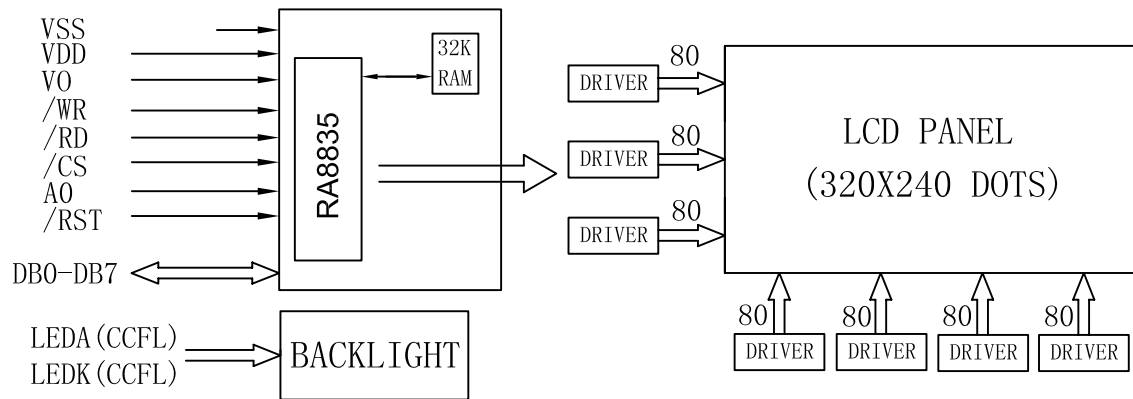

■ ABSOLUTE MAXIMUM RATINGS (Ta = 25°C)

Parameter	Symbol	Min	Max	Unit
Supply voltage for logic	VDD	-0.3	7.0	V
Supply voltage for LCD	VDD - VO	-0.3	30.0	V
Input voltage	VI	-0.3	VDD+0.3	V
Operating temperature	TOP	0	50	°C
Storage temperature	TST	-10	60	°C

■ TIMING DIAGRAMS

◆ SED1330 Timing Diagrams

● System bus READ/WRITE timing I (8080)

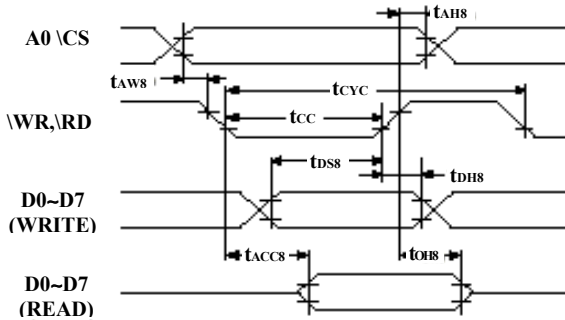

Signal	Symbol	Parameter	Rating		Unit	Condition
			min	max		
A0,CS	tAH8	Address hold time	10	---	ns	CL = 100 pF
	tAW8	Address setup time	30	---	ns	
\WR,\RD	tCYC	System cycle time	(1)	---	ns	
	tCC	Strobe pulsewidth	220	---	ns	
D0 to D7	tDS8	Data setup time	120	---	ns	
	tDH8	Data hold time	10	---	ns	
	tACC8	RD access time	---	120	ns	
	tOH8	Output disable time	10	50	ns	

Note: $t_{CYC} = 2t_C + t_{CC} + t_{CEA} + 75 > t_{ACV} + 245$:
memory control/movement control commands:
 $= 4t_C + t_{CC} + 30$:
all other commands:

● System bus READ/WRITE timing II (6800)

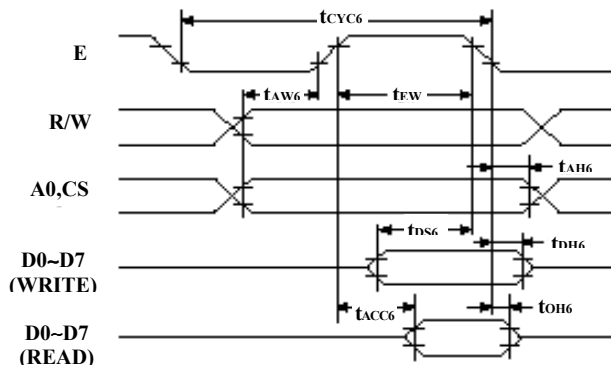

Signal	Symbol	Parameter	Rating		Unit	Condition
			min	max		
A0, \overline{CS} R/W	tAH6	Address hold time	10	---	ns	CL = 100+1TTL pF
	tAW6	Address setup time	30	---	ns	
	tCYC6	System cycle time	(1)	---	ns	
	tCC	Strobe pulsewidth	220	---	ns	
D0 to D7	tDS6	Data setup time	120	---	ns	
	tDH6	Data hold time	10	---	ns	
	tACC6	RD access time	---	120	ns	
	tOH6	Output disable time	10	50	ns	
E	tEW	Enable pulse width	220	---	ns	

Note: (1) $t_{CYC6} = 2t_C + t_{EW} + t_{CEA} + 75 > t_{ACV} + 245$:
memory control/movement control commands:
 $= 4t_C + t_{EW} + 30$:
all other commands:

1. tCYC6 means a cycle of (CS.E) not E alone.

● Display memory READ timing

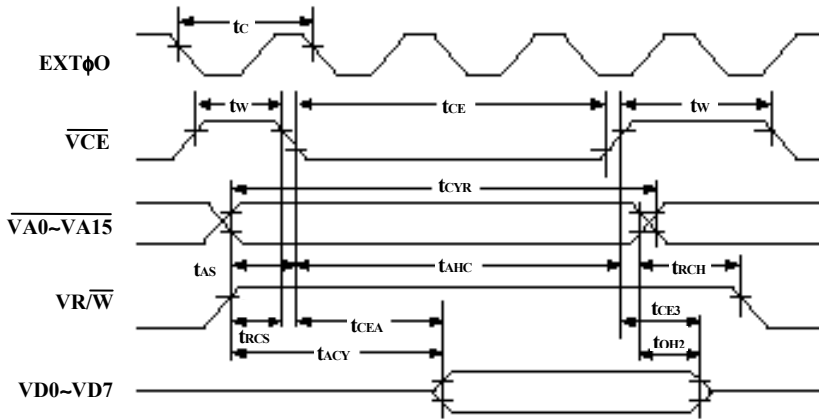

Signal	Symbol	Parameter	Rating		Unit	Condition
			min	max		
EXT ϕ 0	tC	Clock cycle	100	---	ns	CL = 100pF +1TTL
VCE	tW	VCE high level pulse width	tc-40	---	ns	
	tCE	VCE low level pulse width	2tc-40	---	ns	
VA0 to VA15	tCYR	Read cycle time	(1)	---	ns	
	tASC	VCE address setup time (fall)	tc-45	---	ns	
	tAHC	VCE address hold time (fall)	2tc-40	---	ns	
VR/W	tRCS	VCE read cycle setup time (fall)	tc-45	---	ns	
	tRCH	VCE read cycle hold time (fall)	tc/2-35	---	ns	
VD0 to VD7	tACV	Address access time	---	(2)	ns	
	tCEA	VCE access time	---	(3)	ns	
	tOH2	Output data hold time	0	---	ns	
	tCE2	VCE data off time	0	---	ns	

- Note: 1. tCYR = 3tC
 2. tACV = 3tC - 120
 3. tCEA = 2tC - 120

● Display memory WRITE timing

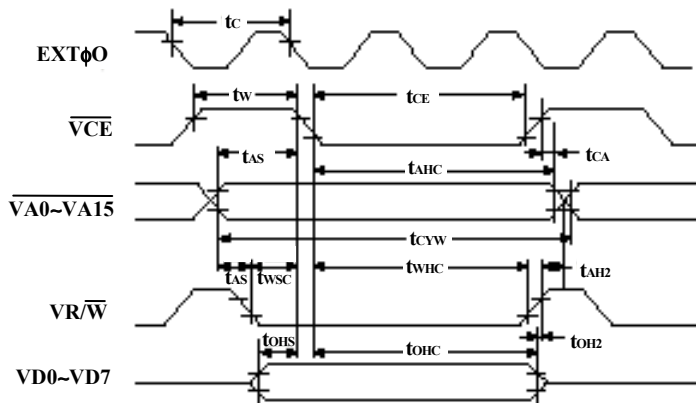

Signal	Symbol	Parameter	Rating		Unit	Condition
			min	max		
EXT ϕ 0	tC	Clock cycle	100	---	ns	CL = 100pF +1TTL
VCE	tW	VCE high level pulse width	tc-40	---	ns	
	tCE	VCE low level pulse width	2tc-40	---	ns	
VA0 to VA15	tCYR	Read cycle time	3tc	---	ns	
	tAHC	VCE address hold time (fall)	2tc-40	---	ns	
	tASC	VCE address setup time (fall)	tc-55	---	ns	
	tCA	VCE address hold time (rise)	5	---	ns	
	tAS	VR/W address setup time (fall)	0	---	ns	
	tAH2	VR/W address hold time (rise)	15	---	ns	
VR/W	tWSC	VCE write setup time (fall)	tc-55	---	ns	
	tWHC	VCE write hold time (fall)	tc/2-40	---	ns	
VD0 to VD7	tDSC	VCE data input setup time (fall)	twsc-10	---	ns	
	tDHC	VCE data input hold time (fall)	2tc-30	---	ns	
	tDH2	VR/W data hold time (rise)	10*	50	ns	

* Lines VD0 to VD7 are latched.

● LCD control timing

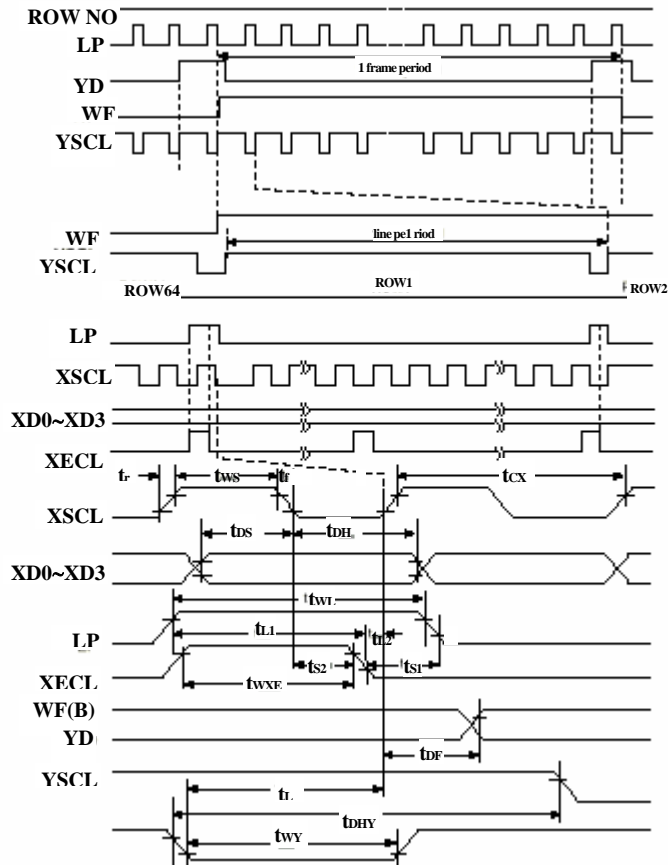

Signal	Symbol	Parameter	Rating		Unit	Condition
			min	max		
EXT \emptyset	tC	Clock cycle	100	---	ns	VDD=5.0V ±10% CL=150F
	tr	VCE high level pulse width	---	35	ns	
	tf	VCE low level pulse width	---	35	ns	
XSCL	tCX	Shift clock cycle time	4tc	---	ns	
	tWX	XSCL clock pulse width	tcx2-80	---	ns	
XD0 to XD3	tDH	X-data hold time	tcx2-100	---	ns	
	tDS	X-data setup time	tcx2-100	---	ns	
LP	tLS	Latch data setup time	tcx2-100	---	ns	
	tWL	LP signal pulse width	tcx4-80	---	ns	
XSCL	tL1	XECL setup time	tc-30	---	ns	
	tL2	XECL data hold time	tc-30	---	ns	
	tS1	Enable setup time	tc-30	---	ns	
	tS1	Enable delay time	tc-30	---	ns	
	tWXE	XECL clock pulse width	tcx3-80	---	ns	
WF	tDF	Time allowance of WF delay	---	100	ns	
YSCL	tLD	LP delay time against YSCL	tcx4-100	---	ns	
	tWY	YSCL clock pulse width	tcx4-80	---	ns	
YD	tDHY	Y-data hold time	tcx6-100	---	ns	

■ FL BACKLIGHT CHARACTERISTICS

◆ Absolute Maximum Ratings

Item	Symbol	Conditions	Standard			Unit
			Min.	Typ.	Max.	
Circuit voltage	V_S		---	---	240	Vrms
Lamp current	I_{FL}	Ta= 25°C	---	---	6	mArms

◆ Electrical Characteristics

Item	Symbol	Conditions	Standard			Unit
			Min.	Typ.	Max.	
Lamp voltage*1	V_{FL}	Ta= 25°C	195	220	235	Vrms
Starting voltage*2	V_S	Ta= 0°C	---	---	400	Vrms
Lamp current*1	I_{FL}	Ta= 25°C	4.0	5.0	6.0	mArms
Frequency*1	f_{FL}	Ta= 25°C	50	---	60	kHz

*1 FL inverter: 13585AQ17

*2 The voltage capable of starting discharge and keeping stable discharge. When the voltage gradually increases, glow discharge will increase and FL tube terminals will be connected electrically.

◆ Optical Characteristics

Item	Symbol	Conditions	Standard			Unit
			Min.	Typ.	Max.	
Surface brightness*1*2*4	Bp	Ta= 25 ±3°C	80	110	---	cd/m ²
Distribution of brightness*1*3	Bp	30~85%RH	---	---	30	%

*1 Measurement 30 minutes after turning on of FL tube

FL inverter: 13585AQ17

FL inverter output voltage and frequency: 220V, 59kHz

LCD driving conditions: Optimum Vopr

LCD display pattern: ALL off display (all data="L")

*2 Initial brightness of LCD panel center

*3 Definition of Bp (Distribution of brightness)

$$Bp = (Bp(\text{max.}) - Bp(\text{min.})) / Bp(\text{max.}) \times 100\%$$

Bp(max.)=Maximum brightness of 5 measuring points

Bp(min.)=Minimum brightness of 5 measuring points

5 measuring points:

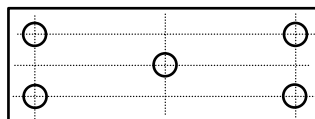

*4 Ambient temperature affects brightness of FL tube. The reason is that radiation efficiency depends on steam pressure of mercury enclosed in the tube. Practically the brightness is low in the cool. As the steam pressure of mercury is also low just after turning on of FL tube, the brightness is low. The heat generated by FL tube will raise temperature on the tube surface, then brightness will increase with a rise in mercury steam pressure.

◆ Life

Item	Conditions	Standard		Unit
		Min.	Max.	
Life*1	Ta= 25 ±3°C	15000	---	hrs

*1 FL driving condition: I_{FL} (Lamp current) = 5 mArms

Time until the decreases to half of the initial brightness, or time until "not lit" because of increase in FL discharge start voltage.

■ OPERATING PRINCIPLES & METHODS

◆ Command Description

● The Command Set

Table 1. The Command Set

Class	Command	Code												Hex	Command Description	Command Read Parameters	
		RD	W R	A0	D7	D6	D5	D4	D3	D2	D1	D0	No. of Bytes			Section	
System	SYSTEM SET	1	0	1	0	1	0	0	0	0	0	0	0	40	Initialize device and display	8	3.2.1
	SLEEP IN	1	0	1	0	1	0	1	0	0	1	1	53	Enter standby	0	3.2.2	
	DISP ON/OFF	1	0	1	0	1	0	1	1	0	0	D	58, 59 Enalbe and disable display and display flashing	1	3.3.1		
Display control	SCROLL	1	0	1	0	1	0	0	0	1	0	0	44	Set display start address and display regions	10	3.3.2	
	CSRFORM	1	0	1	0	1	0	0	0	1	0	0	5D	Set cursor type	2	3.3.3	
	CGRAM ADR	1	0	1	0	1	0	1	1	1	0	0	5C	Set start address of character generator RAM	2	3.3.6	
	CSRDIR	1	0	1	0	1	0	0	1	1	CD 1	CD 0	4Cof 4F	Set direction of cursor movement	0	3.3.4	
	HDOT SCR	1	0	1	0	1	0	1	1	0	1	0	5A	Set horizontal scroll position	1	3.3.7	
	OVLAY	1	0	1	0	1	0	1	1	0	1	1	5B	Set display overlay format	1	3.3.5	
Drawing control	CSRW	1	0	1	0	1	0	0	0	1	1	0	46	Set cursor address	2	3.4.1	
	CSRR	1	0	1	0	1	0	0	0	1	1	1	47	Read cursor address	2	3.4.2	
Memory control	MWRITE	1	0	1	0	1	0	0	0	0	1	0	42	Write to display memory	---	3.5.1	
	MREAD	1	0	1	0	1	0	0	0	0	1	1	43	Read from display memory	---	3.5.2	

Notes:

1. In general, the internal registers of the SED1330F are modified as each command parameter is input. However, the microprocessor does not have to set all the parameters of a command and may send a new command before all parameters have been input. The internal registers for the parameters that have been input will have been changed but the remaining parameter registers are unchanged. 2-byte parameters (where two bytes are treated as one data item) are handled as follows:

a. CSRW, CSRR: Each byte is processed individually. The microprocessor may read or write just the low byte of the cursor address.

b. SYSTEM SET, SCROLL, CGRAM ADR: Both parameter bytes are processed together. If the command is changed after

half of the parameter has been input, the single byte is ignored.

2. APL and APH are 2-byte parameters, but are treated as two 1-byte parameters.

● System Control Commands

1.SYSTEM SET

Initializes the device, sets the window sizes, and selects the LCD interface format. Since the command sets the basic operating parameters of the SED1330F, an incorrect SYSTEM SET command may cause other commands to operate incorrectly.

	MSB								LSB			
	D7	D6	D5	D4	D3	D2	D1	D0	A0	WR	RD	
C	0	1	0	0	0	0	0	0	1	0	1	
P1	DR	T/L	IV	1	W/S	M2	M1	M0	0	0	1	
P2	WF	0	0	0	0	← FX →		0	0	1		
P3	0	0	0	0	← FY →			0	0	1		
P4	← C/R →							0	0	1		
P5	← TC/R →							0	0	1		
P6	← L/F →							0	0	1		
P7	← APL →							0	0	1		
P8	← APH →							0	0	1		

1.1 C

This control byte performs the following:

1. Resets the internal timing generator
2. Disables the display
3. Cancels sleep mode

Parameters following P1 are not needed if only can-celing sleep mode.

1.2 M0

Selects the internal or external character generator ROM. The internal character generator ROM contains 160, 5 × 7 pixel characters. These characters are fixed at fabrication by the metalization mask. The external character generator ROM can contain up to 256 user-defined characters.

M0 = 0: Internal CG ROM

M0 = 1: External CG ROM

Note that if the CG ROM address space overlaps the display memory address space, that portion of the display memory cannot be written to.

1.3 M1

Selects the CG RAM area for user-definable characters. The CG RAM codes are selected from the 64 codes shown in page

M1 = 0: CG RAM1; 32 char

The CG RAM1 and CG RAM2 address spaces are not contiguous, the CG RAM1 address space is treated as character generator RAM, and the CG RAM2 address space is treated as character generator ROM.

M1 = 1: 64 char CG RAM + CG RAM2

The CG RAM1 and CG RAM2 address spaces are contiguous and are both treated as character generator RAM.

1.4 M2

Selects the height of the character defined in external CG ROM and CG RAM. Characters more than 16 pixels high can be displayed by creating a bitmap for each portion of each character and using the SED1330F's graphics mode to reposition them.

M2 = 0: 8-pixel character height (2716 or equivalent ROM)

M2 = 1: 16-pixel character height (2732 or equivalent ROM)

1.5 W/S

Selects the LCD drive method.

W/S = 0: Single-panel drive

W/S = 1: Dual-panel drive

(1) single-panel display

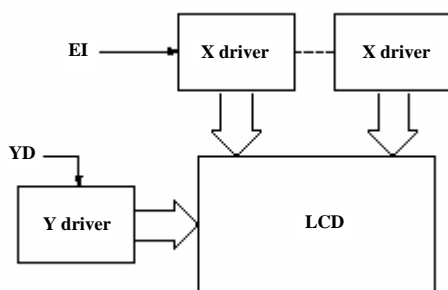

(2) Above and below two-panel display

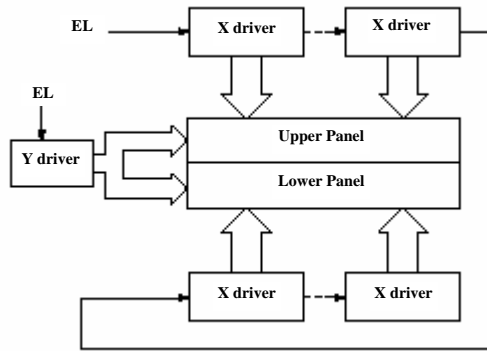

(3) Left and right two-panel display

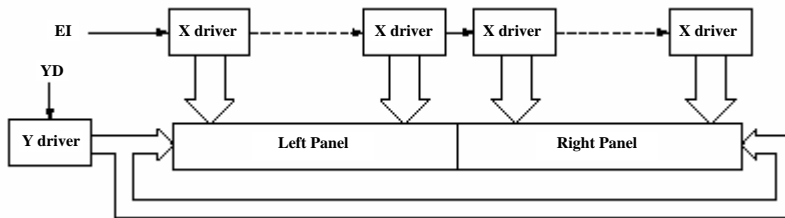

1.6 IV

Screen origin compensation for inverse display. IV is usually set to 1. The best way of displaying inverted characters is to Exclusive-OR the text layer with the graphics back-ground layer. However, inverted characters at the top or left of the screen are difficult to read as the character origin is at the top-left of its bitmap and there are no background pixels either above or to the left of these characters. The IV flag causes the SED1330F to offset the text screen against the graphics back layer by one vertical pixel. Use the horizontal pixel scroll function (HDOT SCR) to shift the text screen 1 to 7 pixels to the right. All characters will then have the necessary surrounding background pixels that ensure easy reading of the inverted characters.

IV = 0: Screen top-line correction

IV = 1: No screen top-line correction (no offset)

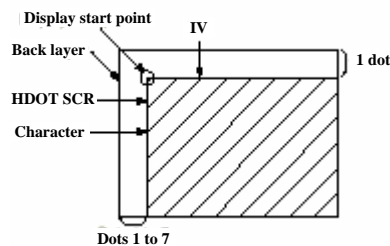

1.7 T/L

Selects TV or LCD mode. When TV mode is selected, the TV sync generator circuit is ON.

T/L = 0: LCD mode

T/L = 1: TV mode

1.8 DR

Selects output of an additional shift-clock cycle for every 64 pixels. The extra cycles are required for correct operation of the enable chain when using a two-panel display.

DR = 0: Normal operation

DR = 1: Additional shift-clock cycles

1.9 FX

Sets the width, in pixels, of the character field. The character width in pixels is equal to FX + 1, where FX can range from 00 to 07H inclusive. If data bit 3 is set (FX is in the range 08 to 0FH) and an 8-pixel font is used, a space is inserted between characters. Note that the maximum character width in TV mode is eight

Since the SED1330F handles display data in 8-bit units, characters larger than 8 pixels wide must be formed from 8-pixel segments. As Figure shows, the remainder of the second eight bits are not displayed. This also applies to the second screen layer.

In graphics mode, the normal character field is also eight pixels. If a wider character field is used, any remainder in the second eight bits is not displayed.

FX					[FX] Character width (pixels)
HEX	D3	D2	D1	D0	
00	0	0	0	0	1
01	0	0	0	1	2
↓	↓	↓	↓	↓	↓
07	0	1	1	1	8

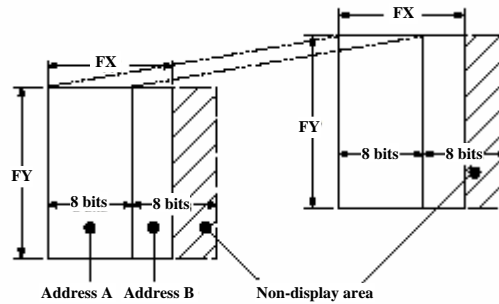

1.10 WF

Selects the AC frame drive waveform period. WF is usually set to 1.

WF = 0: 16-line AC drive

WF = 1: two-frame AC drive

In two-frame AC drive, the WF period is twice the frame period.

In 16-line AC drive, WF inverts every 16 lines. Although 16-line AC drive gives a more readable display, horizontal lines may appear when using high LCD drive voltages or at high viewing angles.

1.11 FY

Sets the height, in pixels, of the character. The height in pixels is equal to FY + 1.

FY can range from 00 to 0FH inclusive.

Set FY to zero (vertical size equals one) when in graphics mode.

Table 5. Vertical character size selection

FX					[FX] Character height (pixels)
HEX	D3	D2	D1	D0	
00	0	0	0	0	1
01	0	0	0	1	2
↓	↓	↓	↓	↓	↓
07	0	1	1	1	8
↓	↓	↓	↓	↓	↓
0E	1	1	1	0	15
0F	1	1	1	1	16

1.12 C/R

Sets the address range covered by one display line, that is, the number of characters less one, multiplied by the number of horizontal bytes per character. C/R can range from 0 to 239.

For example, if the character width is 10 pixels, then the address range is equal to twice the number of characters, less 2. See Section 9.1.1 for the calculation of C/R.

[C/R] cannot be set to a value greater than the address range. It can, however, be set smaller than the address range, in which case the excess display area is blank. The number of excess pixels must not exceed 64.

Table 6. Display line address range

C/R									[C/R] bytes per display line
HEX	D7	D6	D5	D4	D3	D2	D1	D0	
00	0	0	0	0	0	0	0	0	1
01	0	0	0	00	0	0	0	1	2
↓	↓	↓	↓	↓	↓	↓	↓	↓	↓
4F	0	1	0	0	1	1	1	1	80
↓	↓	↓	↓	↓	↓	↓	↓	↓	↓
EE	1	1	1	0	1	1	1	0	239
EF	1	1	1	0	1	1	1	1	240

1.13 TC/R

Sets the length, including horizontal blanking, of one line. The line length is equal to TC/R + 1, where TC/ R can range from 0 to 255.

TC/R must be greater than or equal to C/R + 4. Provided this condition is satisfied, [TC/R] can be set according to the equation given in section 9.1.1 in order to hold the frame period constant and minimize jitter for any given main oscillator frequency, f OSC .

Table 7. Line length selection

TC/R									[C/R] bytes per display line
HEX	D7	D6	D5	D4	D3	D2	D1	D0	
00	0	0	0	0	0	0	0	0	1
01	0	0	0	0	0	0	0	1	2
↓	↓	↓	↓	↓	↓	↓	↓	↓	↓
52	0	1	0	1	0	0	1	0	83
↓	↓	↓	↓	↓	↓	↓	↓	↓	↓
FE	1	1	1	1	1	1	1	0	255
FF	1	1	1	1	1	1	1	1	256

1.14 L/F

Sets the height, in lines, of a frame. The height in lines is equal to L/F + 1, where L/F can range from 0 to 255. If W/S is set to 1, selecting two-screen display, the number of lines must be even and L/F must, therefore, be an odd number.

Table 8. Frame height selection

L/F									[C/R] bytes per display line
HEX	D7	D6	D5	D4	D3	D2	D1	D0	
00	0	0	0	0	0	0	0	0	1
01	0	0	0	0	0	0	0	1	2
↓	↓	↓	↓	↓	↓	↓	↓	↓	↓
7F	0	1	1	1	1	1	1	1	128
↓	↓	↓	↓	↓	↓	↓	↓	↓	↓
FE	1	1	1	1	1	1	1	0	255
FF	1	1	1	1	1	1	1	1	256

Table 9. Frame heights and compatible LCD units

Nombor of linos [LF]	Panel Duty Cycle
64	1/64
128	1/64

1.15 AP

Defines the horizontal address range of the virtual screen. APL is the least significant byte of the ad-dress.

APL

AP7	AP6	AP5	AP4	AP3	AP2	AP1	AP0
-----	-----	-----	-----	-----	-----	-----	-----

APH

AP15	AP14	AP13	AP12	AP11	AP10	AP9	AP8
------	------	------	------	------	------	-----	-----

Table 10. Horizontal address range

Hex code				[AP] addresses per line
APH	APL			
0	0	0	0	0
0	0	0	1	1
↓	↓	↓	↓	↓
0	0	5	0	80
↓	↓	↓	↓	↓
F	F	F	E	2 ¹⁶ - 2
F	F	F	F	2 ¹⁶ - 1

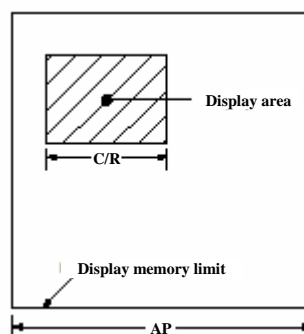

2 SLEEP IN

Places the system in standby mode. This command has no parameter bytes. At least one blank frame after receiving this command, the SED1330F halts all internal operations, including the oscillator, and enters the sleep mode. Blank data is sent to the X-drivers, and the Y-drivers have their bias supplies turned off by the YDIS signal. Using the YDIS signal to disable the Y-drivers guards against any spurious displays.

The internal registers of the SED1330F maintain their values during the sleep mode. The display memory control pins maintain their logic levels to ensure that the display memory is not corrupted.

The SED1330F can be removed from the sleep state by sending the SYSTEM SET command with only the P1 parameter. The DISP ON command should be sent next to enable the display.

MSB	LSB
C	0 1 0 1 0 0 1 1

1. The YDIS signal goes LOW between one and two frames after the SLEEP IN command is received. Since YDIS forces all display driver outputs to go to the deselected output voltage, YDIS can be used as a power-down signal for the LCD unit. This can be done by having YDIS turn off the relatively high-power LCD drive supplies at the same time as it blanks the display.
2. Since all internal clocks in the SED1330F are halted while in the sleep state, a DC voltage will be applied to the LCD panel if the LCD drive supplies remain on. If reliability is a prime consideration, turn off the LCD drive supplies before issuing the SLEEP IN command.
3. Note that, although the bus lines become high impedance in the sleep state, pull-up or pull-down resistors on the bus line will force these lines to a known state.

3 Display Control Commands

3.1 DISP ON/OFF

Turns the whole display on or off. The single-byte parameter enables and disables the cursor and layered screens, and sets the cursor and screen flash rates. The cursor can be set to flash over one character or over a whole line.

MSB	LSB
C	0 1 0 1 1 0 0 0
P1	FP5 FP4 FP3 FP2 FP1 FP0 FC1 FC0

DISP ON/OFF parameters

3.1.1 D

Turns the display ON or OFF. The D bit takes precedence over the FP bits in the parameter.

D = 0: Display OFF

D = 1: Display ON

3.1.2 FC

Enables/disables the cursor and sets the flash rate. The cursor flashes with a 70% duty cycle (ON/OFF).

Table 11. Cursor flash rate selection

FC1	FC0	Cursor display	
0	0	OFF (blank)	
0	1	ON	No flashing
1	0		Flash at f _{FR} /32Hz (approx. 2 Hz)
1	1		Flash at f _{FR} /64 Hz (approx. 1 Hz)

Note: As the MWRITE command always enables the cursor, the cursor position can be checked even when performing consecutive writes to display memory while the cursor is flashing.

3.1.3 FP

Each pair of bits in FP sets the attributes of one screen block, as follows.

Table 12. Screen block attribute selection

FP1	FP0	First screen block (SAD1)	
FP3	FP2	Second screen block (SAD2,SAD4). See note.	
FP5	FP4	Third screen block (SAD3)	
0	0	OFF (blank)	
0	1	ON	No flashing
1	0		Flash at $f_{FR}/32Hz$ (approx. 2 Hz)
1	1		Flash at $f_{FR}/4 Hz$ (approx. 16 Hz)

Note: If SAD4 is enabled by setting W/S to 1, FP3 and FP2 control both SAD2 and SAD4. The attributes of SAD2 and SAD4 cannot be set independently.

3.2 SCROLL

3.2.1 C

Sets the scroll start address and the number of lines per scroll block. Parameters P1 to P10 can be omitted if not required. The parameters must be entered sequentially as shown in Figure 17.

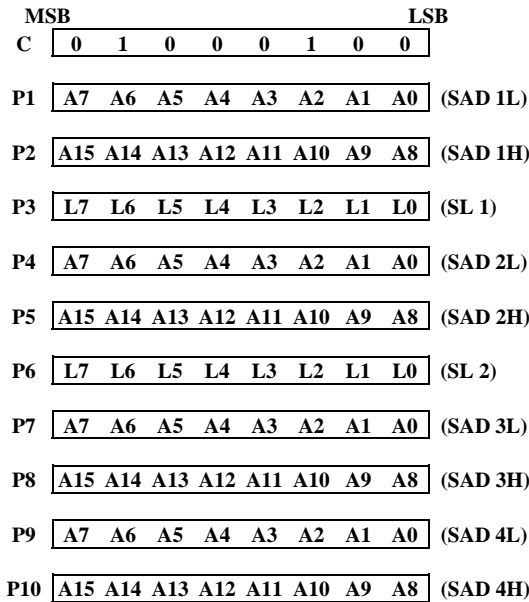

Note : Set parameters P9 and P10 only if both two-screen drive (W/S=1) and two-layer configuration are selected. SAD4 is the fourth screen block display start address.

Figure 17. SCROLL instruction parameters

Note: Set parameters P9 and P10 only if both two-screen drive (W/S = 1) and two-layer configuration are selected. SAD4 is the fourth screen block display start address.

Table 13. Screen block start address selection

		SL1,SL2								[SL] screen lines
HEX	L7	L6	L5	L4	L3	L2	L1	L0		
00	0	0	0	0	0	0	0	0	1	
01	0	0	0	0	0	0	0	1	2	
↓	↓	↓	↓	↓	↓	↓	↓	↓	↓	
7F	0	1	1	1	1	1	1	1	128	
↓	↓	↓	↓	↓	↓	↓	↓	↓	↓	
FE	1	1	1	1	1	1	1	0	255	
FF	1	1	1	1	1	1	1	1	256	

3.2.2 SL1, SL2

SL1 and SL2 set the number of lines per scrolling screen. The number of lines is SL1 or SL2 plus one. The relationship between SAD, SL and the display mode is described below.

Table 14. Text display mode

W/S	Screen	First Layer	Second Layer
1	First screen block	SAD1 SL1	SAD2 SL2
	Lower screen	SAD3 (see note 2)	SAD4 (see note 2)
	Set both SL1 and SL2 to $((L/F)/2+1)$		
Screen configuration example:			

Notes:

- SAD3 has the same value as either SAD1 or SAD2, whichever has the least number of lines (set by SL1 and SL2).
- Since the parameters corresponding to SL3 and SL4 are fixed by L/F, they do not have to be set in this mode.

Table 15. Graphics display mode

W/S	Screen	First Layer	Second Layer	Third Layer
0	Upper screen	SAD1 SL1	SAD2 SL2	
	Lower screen	SAD3 (see note 3) Set both SL1 and SL2 to $L/F + 1$ if not using a partitioned screen		
	Screen configuration example:			
0	Three-layer configuration	SAD1 $SL1 = L/F + 1$	SAD1 $SL2 = L/F + 1$	SAD3 —
	Screen configuration example:			

Table 15. Graphics display mode (continued)

W/S	Screen	First Layer	Second Layer	Third Layer
1	Upper screen	SAD1 SL1	SAD2 SL2	—
	Lower screen	SAD3 (see note 2)	SAD4 (see note 2)	—
	Set both SL1 and SL2 to $((L/F)/2+1)$			
Screen configuration example (see note 3):				
<p>The diagram illustrates a screen configuration with two layers, Layer 1 and Layer 2. Layer 1 contains two 'Character display page' blocks. Layer 2 contains two 'Graphics display page' blocks. Arrows indicate connections: SAD1 points to the top of the first character page, SAD2 points to the top of the first graphics page, and SAD3 points to the top of the second character page. SL1 is shown as a vertical line on the left side of the character pages. The graphics pages are positioned to the right of the character pages.</p>				

Notes :

1. SAD3 has the same value as either SAD1 or SAD2, whichever has the least number of lines (set by SL1 and SL2).
2. Since the parameters corresponding to SL3 and SL4 are fixed by L/F, they do not have to be set.
3. If, and only if, W/S = 1, the differences between SL1 and $(L/F + 1) / 2$, and between SL2 and $(L/F + 1) / 2$, are blanked.

3.3 CSRFORM

Sets the cursor size and display mode. Although the cursor is normally only used in text displays, it may also be used in graphics displays when displaying special characters.

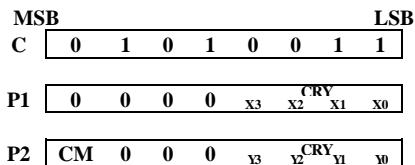

Figure 19. CSRFORM parameter bytes

3.3.1 CRX

Sets the horizontal size of the cursor from the character origin. CRX is equal to the cursor size less one. CRX must be less than or equal to FX.

Table 16. Horizontal cursor size selection

HEX	CRX				[CRX] cursor width pixels
	X3	X2	X1	X0	
0	0	0	0	0	1
1	0	0	0	1	2
↓	↓	↓	↓	↓	↓
8	1	0	0	0	9
↓	↓	↓	↓	↓	↓
E	1	1	1	0	15
F	1	1	1	1	16

3.3.2 CRY

Sets the location of an underscored cursor in lines, from the character origin. When using a block cursor,CRY sets the vertical size of the cursor from the character origin. CRY is equal to the number of lines less one.

Table 17. Cursor height selection

CRX					[CRX] cursor height (lines)
HEX	X3	X2	X1	X0	
0	0	0	0	0	illegal
1	0	0	0	1	2
↓	↓	↓	↓	↓	↓
8	1	0	0	0	9
↓	↓	↓	↓	↓	↓
E	1	1	1	0	15
F	1	1	1	1	16

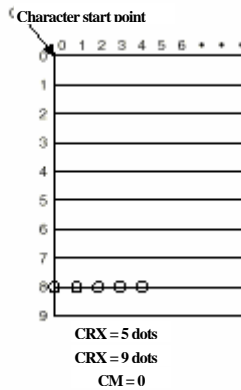

Figure 20. Cursor size and position

3.3.3 CM

Sets the cursor display mode. Always set CM to 1 when in graphics mode.

CM = 0: Underline cursor

CM = 1: Block cursor

3.4 CSRDIR

Sets the direction of automatic cursor increment. The cursor can move left or right one character, or up or down by the number of bytes specified by the address pitch, AP.

When reading from and writing to display memory, this automatic cursor increment controls the display memory address increment on each read or write. in character units. See Section 5.3.

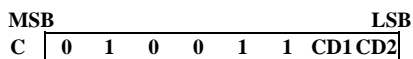

Figure 21. CSRDIR parameters

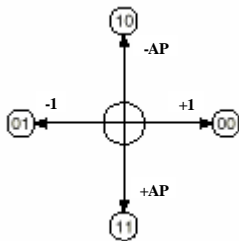

Figure 22. Cursor direction

Table 18. Cursor shift direction

C	CD1	CD0	Shift direction
4CH	0	0	Right
4DH	0	1	Left
4EH	1	0	Up
4FH	1	1	Down

Note: Since the cursor moves in address units even if FX³9, the cursor address increment must be preset for movement in character units. See Section 5.3.

3.3.5 OVLAY

Selects layered screen composition and screen text/ graphics mode.

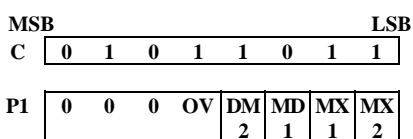

Figure 23. OVLAY parameter

3.5.1 MX0, MX1

MX0 and MX1 set the layered screen composition method, which can be either OR, AND, Exclusive-OR or Priority-OR. Since the screen composition is organized in layers and not by screen blocks, when using a layer divided into two screen blocks, different composition methods cannot be specified for the individual screen blocks.

The Priority-OR mode is the same as the OR mode unless flashing of individual screens is used.

Table 19. Composition method selection

MX1	MX0	Function	Composition Method	Applications
0	0	$L1 \cup L2 \cup L3$	OR	Underlining, rules, mixed text and graphics
0	1	$(L1 \oplus L2) \cup L3$	Exclusive-OR	Inerted characters, flashing regions, underlining
1	0	$(L1 \cap L2) \cup L3$	AND	Simple animation, three-dimensional
1	1	$L1 > L2 > L3$	Priority-OR	appearance

Notes:

L1: First layer (text or graphics). If text is selected, layer L3 cannot be used.

L2: Second layer (graphics only)

L3: Third layer (graphics only)

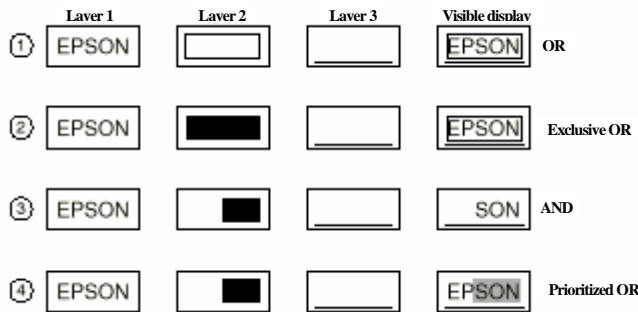

Figure 24. Combined layer display

Notes:

L1: Not flashing

L2: Flashing at 1 Hz

L3: Flashing at 2 Hz

3.5.2 DM1, DM2

DM1 and DM2 specify the display mode of screen blocks 1 and 3, respectively.

DM1/2 = 0: Text mode

DM1/2 = 1: Graphics mode

Note 1: Screen blocks 2 and 4 can only display graphics.

Note 2: DM1 and DM2 must be the same, regardless of the setting of W/S.

3.5.3 OV

Specifies two- or three-layer composition in graphics mode.

OV = 0: Two-layer composition

OV = 1: Three-layer composition

Set OV to 0 for mixed text and graphics mode.

3.6 CGRAM ADR

Specifies the CG RAM start address.

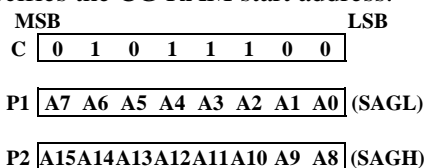

Figure 25. CGRAM ADR parameters

3.7 HDOT SCR

While the scroll command only allows scrolling by characters, HDOT SCR allows the screen to be scrolled horizontally by pixels. HDOT SCR cannot be used on individual layers.

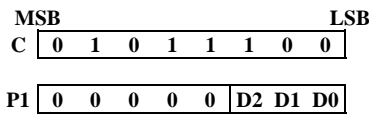

Figure 26. HDOT SCR parameters

3.7.1 D0 to D2

Specifies the number of pixels to scroll. The C/R parameter has to be set to one more than the number of horizontal characters before using HDOT SCR. Smooth scrolling can be simulated if the controlling microprocessor repeatedly issues the HDOT SCR command to the SED1330F

Table 20. Scroll step selection

HEX	P1			Number of pixels to scroll
	D2	D1	D0	
00	0	0	0	0
01	0	0	1	1
02	0	1	0	2
↓	↓	↓	↓	↓
06	1	1	0	6
07	1	1	1	7

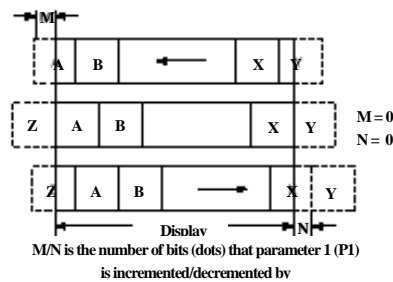

Figure 27. Horizontal scrolling

4 Drawing Control Commands

4.1 CSRW

The 16-bit cursor address register contains the display memory of the data at the cursor position as shown in Figure 28.

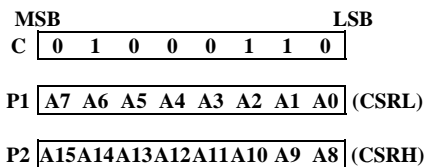

Figure 28. CSRW parameters

Note that the microprocessor cannot directly access the display memory.

The MREAD and MWRITE commands use the address in this register.

The cursor address register can only be modified by the CSRW command, and by the automatic increment after an MREAD or MWRITE command. It is not affected by display scrolling.

4.2 CSRR

Reads from the cursor address register. After issuing the command, the data read address is read twice, for the low byte and then the high byte of the register.

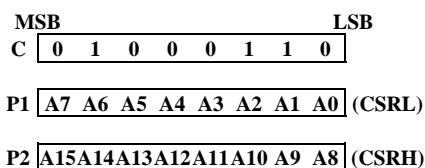

Figure 29. CSRR parameters

5 Memory Control Commands

5.1 MWRITE

The microprocessor may write a sequence of data bytes to display memory by issuing the MREAD command and then writing the bytes to the SED1330F. There is no need for further MWRITE commands or for the microprocessor to update the cursor address register after each byte as the cursor address is automatically incremented by the amount set with CSRDIR, in preparation for the next data write.

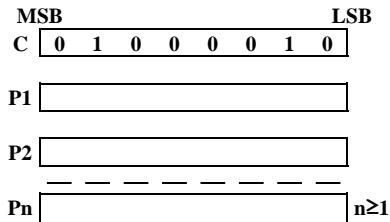

Figure 30. MWRITE parameters

5.2 MREAD

Puts the SED1330F/1335F/1336F into the data out-put state. On the MREAD command, the display memory data at the cursor address is read into a buffer in the SED1330F

Each time the microprocessor reads the buffer, the cursor address is incremented by the amount set by CSRDIR and the next data byte fetched from memory,so a sequence of data bytes may be read without further MREAD commands or by updating the cursor address register.

If the cursor is displayed, the read data will be from two positions ahead of the cursor.

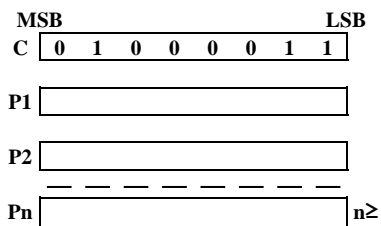

Figure 31. MREAD parameters

6 Internal Character Generator Font

		Character code bits 0 to 3															
		0	1	2	3	4	5	6	7	8	9	A	B	C	D	E	F
Character code bits 4 to 7	2		!	"	#	\$	%	&	'	()	*	+	,	-	.	/
	3	0	1	2	3	4	5	6	7	8	9	:	;	<	=	>	?
	4	@	A	B	C	D	E	F	G	H	I	J	K	L	M	N	O
	5	P	Q	R	S	T	U	V	W	X	Y	Z	[]	^	_	`
	6	`	a	b	c	d	e	f	g	h	i	j	k	l	m	n	o
	7	p	q	r	s	t	u	v	w	x	y	z	{	}	~	`	`
	A		`	`	`	`	`	`	`	`	`	`	`	`	`	`	`
	B	`	`	`	`	`	`	`	`	`	`	`	`	`	`	`	`
	C	`	`	`	`	`	`	`	`	`	`	`	`	`	`	`	`
	D	`	`	`	`	`	`	`	`	`	`	`	`	`	`	`	`
1																	

Figure 94. On-chip character set

7 Application Subprogram

```

ORG 0000H
AJMP MAIN
;直接访问方式地址定义,根据用户平台接口修改
CWADD1 EQU 0101H ;写指令代码地址
DWADD1 EQU 0000H ;写参数及显示数据地址
DRADD1 EQU 0101H ;读参数及显示数据地址
CRADD1 EQU 0000H ;读忙状态地址
;间接控制方式信号定义,根据用户平台接口修改
;RSEQU P3.0 ;RS
;RD EQU P3.1 ;/RD
;WR EQU P3.2 ;/WR
DATBUS EQU P1 ;数据总线
;-----
PARA1 EQU 30H ;应用于含1335控制器的液晶模块(320*240)
;----- CA320240 + 1335 的SYSTEM SET 参数 -----
SYSTAB: DB 30H,87H,07H,27H,42H,0F0H,30H,00H ;P1-P8参数
SCR TAB: DB 00H,00H,0F0H,00H,40H,0F0H,00H,80H,00H,00H ;P1-P10参数
;程序变量定义,根据用户平台提供的内部资源修改
COM EQU 30H ;指令寄存器
DAT1 EQU 31H ;参数及显示数据寄存器
COUNT1 EQU 32H ;计数器1
COUNT2 EQU 33H ;计数器2
O_XL EQU 34H ;X坐标低8位寄存器(字节)
O_XH EQU 35H ;X坐标高8位寄存器(点列)
;D7位为绘点(D7=1)和消点(D7=0)标志位
O_YL EQU 36H ;Y坐标寄存器(字符行/点行)
COOE EQU 37H ;汉字代码
CFLUG EQU 10H ;位标志。表示字符的写入方式
;CFLUG=1为初次写入;CFLUG=0为接续写入
TEMP1 EQU 28H
TEMP2 EQU 29H
ORG 0040H
MAIN: LCALL DELAY
MOV SP,#60H
LCALL INT
LCALL CLEAR
; LJMP DISCHA
;图形方式下汉字显示方法
DISCHA: MOV O_XL,#00H ;设置X坐标
MOV O_YL,#00H ;设置Y坐标
MOV COOE,#00H ;设置汉字代码
LCALL CCW2_PR ;调汉字写入子程序
MOV O_XL,#04H ;设置X坐标
MOV O_YL,#00H ;设置Y坐标
MOV COOE,#01H ;设置汉字代码
LCALL CCW2_PR ;调汉字写入子程序
MOV O_XL,#08H ;设置X坐标
MOV O_YL,#00H ;设置Y坐标
MOV COOE,#02H ;设置汉字代码
LCALL CCW2_PR ;调汉字写入子程序
MOV O_XL,#0CH ;设置X坐标
MOV O_YL,#00H ;设置Y坐标
MOV COOE,#03H ;设置汉字代码
LCALL CCW2_PR ;调汉字写入子程序
SJMP $
;-----延时子程序-----
DELAY: MOV R2,#01H ;延时子程序
MOV R3,#01H
DEL1: NOP
DJNZ R3,DEL1
DJNZ R2,DEL1
RET

```

```

    RET
; 写指令代码子程序
PR1:  PUSH DPL
      PUSH DPH
      MOV  DPTR,#CWADD1
      MOV  A,COM
      MOVX @DPTR,A
      POP  DPH
      POP  DPL
      RET
;-----
; 写参数及显示数据子程序
PR2:  PUSH DPL
      PUSH DPH
      MOV  DPTR,#DWADD1
      MOV  A,DAT1
      MOVX @DPTR,A
      POP  DPH
      POP  DPL
      RET
;-----
; 读参数及显示数据子程序
PR3:  PUSH DPL
      PUSH DPH
      MOV  DPTR,#DRADD1
      MOVXA,@DPTR
      MOV  DAT1,A
      POP  DPH
      POP  DPL
      RET
;=====
; 初始化子程序INT
; 内部调用子程序：PR1,PR2
; 程序调用入口：INT
; 程序参数库:SYSTAB,SCR TAB
; 程序调用变量：无
;=====
INT:  MOV  COM,#40H      ; SYSTEM SET 代码
      LCALL PR1        ; 写入指令代码
      MOV  COUNT1,#00H  ; 设置计数器COUNT=0
INT3: MOV  DPTR,#SYSTAB ; 设置指令参数表地址
      MOV  A,COUNT1     ; 取参数
      MOVC A,@A+DPTR
      MOV  DAT1,A
      LCALL PR2        ; 写入参数
      INC  COUNT1      ; 计数器加一
      MOV  A,COUNT1
      CJNE A,#08H,INT3 ; 循环
      MOV  COM,#44H    ; SCROLL 代码
      LCALL PR1        ; 写入指令代码
      MOV  COUNT1,#00H ; 设置计数器COUNT=0
INT2: MOV  DPTR,#SCR TAB ; 设置指令参数表地址
      MOV  A,COUNT1     ; 取参数
      MOVC A,@A+DPTR
      MOV  DAT1,A
      LCALL PR2        ; 写入参数
      INC  COUNT1
      MOV  A,COUNT1    ; 计数器加一
      CJNE A,#0AH,INT2 ; 循环
      MOV  COM,#5AH    ; HDOT SCR 代码
      LCALL PR1        ; 写入指令代码
      MOV  DAT1,#00H   ; 设置参数P1
      LCALL PR2        ; 写入参数
      MOV  COM,#5BH    ; OVLAY 代码
      LCALL PR1        ; 写入指令代码

```



```

MOV DAT1,#00H      ;设置参数:显示一,三区为文本属性
LCALL PR2          ;二重"或"合成
MOV COM,#59H       ;DISP ON/OFF 代码
LCALL PR1          ;写入指令代码
MOV DAT1,#54H      ;设置参数:显示一~四区开显示 0101 0100
LCALL PR2          ;光标关显示
RET

```

```

;=====
; 汉字写入子程序(图形方式)CCW2_PR
; 占用内部资源: O_XL,O_YL,COOE,COUNT1,A,B,DPTR
; 内部调用子程序: PR1
; 连接字库: CCTAB
; 程序调用入口: CCW2_PR
; 程序输入变量: O_XL,O_YL,COOE
;=====

```

```

CCW2_PR:MOV A,COOE      ;计算汉字字模数据首地址
MOV B,#128D
MUL AB
MOV DPTR,#CGTAB      ;汉字库入口地址
ADD A,DPL
MOV DPL,A
MOV A,B
ADDC A,DPH
MOV DPH,A
MOV TEMP1,DPL
MOV TEMP2,DPH
MOV A,O_YL          ;计算光标地址
MOV B,#PARA1        ;PARA1值等于SYSTEM SET 指令P9
MUL AB              ;而P10=0
ADD A,O_XL
MOV O_XL,A          ;存光标地址低字节
MOV A,B
ADDC A,#40H         ;加入显示二区起始地址SAD2H
MOV O_YL,A          ;存光标地址高字节
MOV COM,#4FH        ;CSRDIR 代码(右移)
LCALL PR1
MOV COUNT1,#4D      ;设置计数器1=2
CCW2_1:MOV COM,#46H   ;CSRW 代码
LCALL PR1
MOV DAT1,O_XL       ;设置光标地址CSR
LCALL PR2
MOV DAT1,O_YL
LCALL PR2
MOV COM,#42H        ;MWRITE 代码
LCALL PR1
MOV COUNT2,#32D     ;设置计数器2=16
CCW2_2:CLRA
MOVC A,@A+DPTR     ;取字模数据
MOV DAT1,A
INC DPTR           ;指针加一
INC DPTR
INC DPTR
INC DPTR
LCALL PR2          ;写入数据
DJNZ COUNT2,CCW2_2 ;循环
MOV A,O_XL         ;修正光标地址
ADD A,#01H         ;(加一)
MOV O_XL,A
MOV A,O_YL
ADDC A,#00H
MOV O_YL,A
MOV DPL,TEMP1
MOV DPH,TEMP2
INC DPTR
MOV TEMP1,DPL

```

```

MOV  TEMP2,DPH
DJNZ  COUNT1,CCW2_1  ;循环
RET

;=====
; 清显示RAM 区(清屏)子程序CLEAR
; 占用内部寄存器 : COM,DAT1,A,R3,R4
; 内部调用子程序 : PR1,PR2
; 程序输入变量 : 无
; 程序调用入口 : CLEAR
;=====
CLEAR:  MOV  COM,#4CH      ; CSRDIR 代码
        LCALL PR1        ; 写入指令代码
        MOV  COM,#46H    ; CSRW 代码
        LCALL PR1        ; 写入指令代码
        MOV  DAT1,#00H   ; 设置参数光标指针低8位
        LCALL PR2        ; 写入参数CSRL
        LCALL PR2        ; 写入参数CSRH
        MOV  COM,#42H    ; MWRITE 代码
        LCALL PR1        ; 写入指令代码
        MOV  R3,#00H     ; 设置循环量0000H
        MOV  R4,#00H
        MOV  DAT1,#00H   ; 设置显示数据=0
CLR1:
        LCALL PR2        ; 写入数据
        DJNZ R3,CLR1     ; 循环
        DJNZ R4,CLR1
        RET
CGTAB:
;-- 文字: 美 -- ;-- 华文行楷24; 此字体下对应的点阵为: 宽x高=32x33 --
DB  000H,000H,030H,000H,000H,002H,030H,000H,000H,03EH,030H,000H,000H,01CH,070H,000H
DB  000H,01CH,0E0H,000H,000H,01DH,0F0H,000H,000H,00FH,0F0H,000H,000H,03FH,0F0H,000H
DB  000H,0FFH,0C0H,000H,000H,07BH,0E0H,000H,000H,007H,0E0H,000H,000H,00FH,0E0H,000H
DB  000H,03FH,0C0H,000H,000H,07FH,0F0H,000H,000H,077H,0F8H,000H,000H,02FH,0E0H,000H
DB  000H,03FH,080H,000H,000H,0FDH,098H,000H,000H,0FBH,09CH,000H,000H,063H,01CH,000H
DB  01FH,0FBH,018H,000H,020H,01FH,030H,000H,020H,00FH,0E0H,000H,010H,03EH,0FCH,000H
DB  00FH,0FCH,01FH,000H,003H,0E0H,007H,0C0H,000H,000H,001H,0E0H,000H,000H,000H,0F0H
DB  000H,000H,000H,030H,000H,000H,000H,000H,000H,000H,000H,000H,000H,000H,000H,000H
;-- 文字: 视 -- ;-- 华文行楷24; 此字体下对应的点阵为: 宽x高=32x33 --
DB  000H,000H,000H,000H,000H,000H,000H,000H,000H,000H,000H,000H,000H,0E0H,03CH,000H
DB  000H,078H,07EH,000H,000H,0F8H,0F3H,000H,001H,0F9H,083H,000H,002H,001H,003H,000H
DB  00CH,001H,0F3H,000H,010H,065H,09BH,000H,001H,0F9H,09BH,000H,043H,0F9H,09BH,000H
DB  04FH,0F9H,0BBH,000H,03FH,071H,033H,000H,03EH,071H,073H,000H,01CH,0E1H,077H,000H
DB  000H,0E1H,0FFH,000H,001H,0C0H,0FEH,000H,003H,0C0H,0DCH,000H,007H,0C1H,0DCH,000H
DB  00FH,041H,098H,004H,00EH,0C3H,030H,004H,00CH,0C6H,030H,006H,000H,0CCH,030H,01EH
DB  000H,0C0H,03FH,0FEH,000H,0C0H,00FH,0F8H,000H,040H,000H,000H,000H,000H,000H,000H
DB  000H,000H,000H,000H,000H,000H,000H,000H,000H,000H,000H,000H,000H,000H,000H,000H
;-- 文字: 电 -- ;-- 华文行楷24; 此字体下对应的点阵为: 宽x高=32x33 --
DB  000H,000H,000H,000H,000H,000H,000H,000H,00EH,000H,000H,000H,00FH,000H,000H
DB  000H,007H,000H,000H,000H,007H,080H,000H,000H,003H,080H,000H,000H,003H,080H,000H
DB  000H,003H,0FCH,000H,000H,00FH,0FFH,000H,004H,03FH,007H,080H,007H,07FH,007H,0C0H
DB  007H,0C7H,0C7H,0C0H,007H,08FH,0CFH,080H,003H,0BFH,0EFH,000H,003H,0FFH,09EH,000H
DB  003H,09FH,03CH,000H,003H,0BEH,0B8H,000H,001H,0FFH,0F8H,000H,001H,0FFH,0F8H,000H
DB  000H,0FFH,000H,000H,000H,0FEH,000H,000H,000H,00FH,000H,000H,000H,000H,007H,0FEH,000H
DB  000H,003H,0FFH,000H,000H,000H,0FFH,000H,000H,000H,000H,000H,000H,000H,000H,000H
DB  000H,000H,000H,000H,000H,000H,000H,000H,000H,000H,000H,000H,000H,000H,000H,000H
;-- 文字: 子 -- ;-- 华文行楷24; 此字体下对应的点阵为: 宽x高=32x33 --
DB  000H,000H,000H,000H,000H,000H,010H,000H,000H,000H,078H,000H,000H,019H,0ECH,000H
DB  000H,00FH,09EH,000H,000H,00FH,01CH,000H,000H,03EH,03CH,000H,000H,03CH,070H,000H
DB  000H,079H,0E0H,000H,000H,073H,0C0H,000H,000H,023H,0E0H,000H,000H,003H,0F0H,000H
DB  000H,003H,0FEH,000H,000H,001H,0FFH,000H,000H,007H,0FFH,080H,000H,01FH,01FH,080H
DB  000H,07CH,018H,000H,000H,0F8H,018H,000H,000H,0F0H,018H,000H,000H,0E0H,018H,000H
DB  000H,0C0H,018H,000H,000H,040H,018H,000H,000H,060H,018H,000H,000H,030H,030H,000H
DB  000H,01EH,030H,000H,000H,007H,0F0H,000H,000H,003H,0E0H,000H,000H,000H,0C0H,000H
DB  000H,000H,000H,000H,000H,000H,000H,000H,000H,000H,000H,000H,000H,000H,000H,000H

```

END

■ ELECTRO-OPTICAL CHARACTERISTICS ($V_{OP} = 13.8V$, $T_a = 25^{\circ}C$)

Item	Symbol	Condition	Min	Typ	Max	Unit	Remarks	Note
Response time	Tr	---	---	140	---	ms	---	1
	Tf	---	---	133	---	ms	---	1
Contrast ratio	Cr	---	---	5.1	---	---	---	2
Viewing angle range	θ	$Cr \geq 2$	41	---	---	deg	$\varnothing = 90^{\circ}$	3
			38	---	---	deg	$\varnothing = 270^{\circ}$	3
			32	---	---	deg	$\varnothing = 0^{\circ}$	3
			19	---	---	deg	$\varnothing = 180^{\circ}$	3

Note1: Definition of response time.

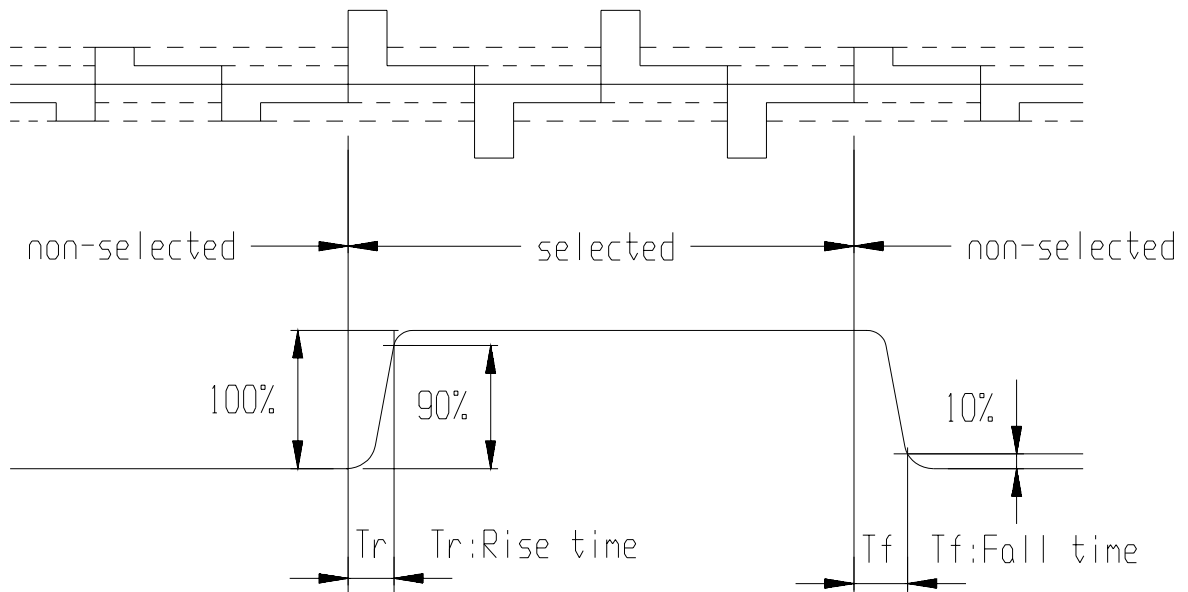

Note2: Definition of contrast ratio 'Cr' .

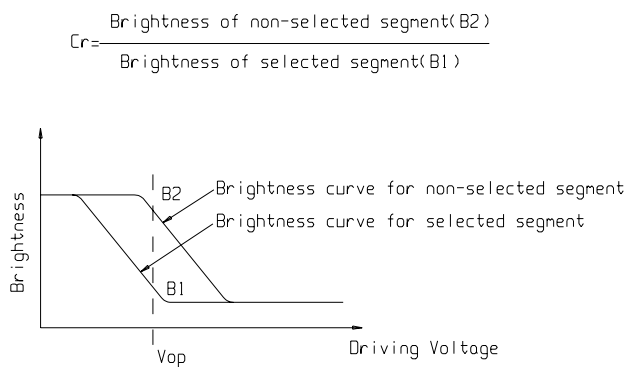

Note3: Definition of viewing angle range 'θ'.

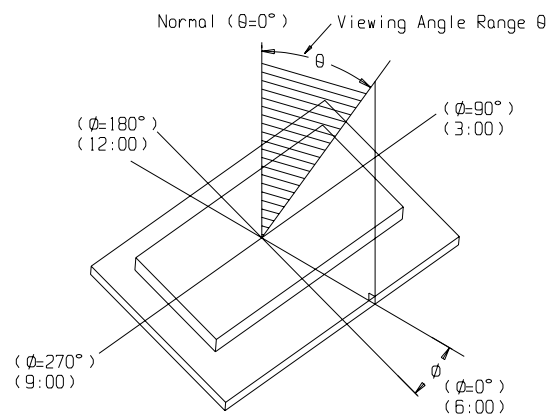

■ QUALITY GUARANTEE

◆ Acceptable Quality Level

Each lot should satisfy the quality level defined as follows.

- Inspection method : MIL-STD-105E LEVEL II Normal one time sampling
- AQL

Partition	AQL	Definition
A: Major	0.4%	Functional defective as product
B: Minor	1.5%	Satisfy all functions as product but not satisfy cosmetic standard

◆ Definition of 'LOT'

One lot means the delivery quantity to customer at one time.

◆ Conditions of Cosmetic Inspection

- Environmental condition

The inspection should be performed at the 1m of height from the LCD module under 2 pieces of 40W white fluorescent lamps (Normal temperature 20~25°C and normal humidity 60±15%RH).

- Inspection method

The visual check should be performed vertically at more than 30cm distance from the LCD panel.

- Driving voltage

The V_o value which the most optimal contrast can be obtained near the specified V_o in the specification. (Within ±0.5V of the typical value at 25°C.).

■ INSPECTION CRITERIA

◆ Module Cosmetic Criteria

No.	Item	Judgement Criterion	Partition
1	Difference in Spec.	None allowed	Major
2	Pattern peeling	No substrate pattern peeling and floating	Major
3	Soldering defects	No soldering missing No soldering bridge No cold soldering	Major Major Minor
4	Resist flaw on substrate	Invisible copper foil (∅0.5mm or more) on substrate pattern	Minor
5	Accretion of metallic Foreign matter	No soldering dust No accretion of metallic foreign matters (Not exceed ∅0.2mm)	Minor Minor
6	Stain	No stain to spoil cosmetic badly	Minor
7	Plate discoloring	No plate fading, rusting and discoloring	Minor
8	Solder amount	a. Soldering side of PCB Solder to form a 'Filet' all around the lead. Solder should not hide the lead form perfectly. (too much)	Minor
	1. Lead parts	b. Components side (In case of 'Through Hole PCB') Solder to reach the Components side of PCB.	
	2. Flat packages	Either 'toe' (A) or 'heel' (B) of the lead to be covered by 'Filet'. Lead form to be assume over solder.	
	3. Chips	$(3/2) H \geq h \geq (1/2) H$	Minor

◆ Screen Cosmetic Criteria (Non-Operating)

No.	Defect	Judgement Criterion	Partition										
1	Spots	In accordance with <i>Screen Cosmetic Criteria (Operating) No.1.</i>	Minor										
2	Lines	In accordance with <i>Screen Cosmetic Criteria (Operating) No.2.</i>	Minor										
3	Bubbles in polarizer	<table border="1"> <thead> <tr> <th>Size : d mm</th> <th>Acceptable Qty in active area</th> </tr> </thead> <tbody> <tr> <td>$d \leq 0.3$</td> <td>Disregard</td> </tr> <tr> <td>$0.3 < d \leq 1.0$</td> <td>3</td> </tr> <tr> <td>$1.0 < d \leq 1.5$</td> <td>1</td> </tr> <tr> <td>$1.5 < d$</td> <td>0</td> </tr> </tbody> </table>	Size : d mm	Acceptable Qty in active area	$d \leq 0.3$	Disregard	$0.3 < d \leq 1.0$	3	$1.0 < d \leq 1.5$	1	$1.5 < d$	0	Minor
Size : d mm	Acceptable Qty in active area												
$d \leq 0.3$	Disregard												
$0.3 < d \leq 1.0$	3												
$1.0 < d \leq 1.5$	1												
$1.5 < d$	0												
4	Scratch	In accordance with spots and lines operating cosmetic criteria. When the light reflects on the panel surface, the scratches are not to be remarkable.	Minor										
5	Allowable density	Above defects should be separated more than 30mm each other.	Minor										
6	Coloration	Not to be noticeable coloration in the viewing area of the LCD panels. Back-lit type should be judged with back-lit on state only.	Minor										
7	Contamination	Not to be noticeable.	Minor										

◆ Screen Cosmetic Criteria (Operating)

No.	Defect	Judgement Criterion	Partition																				
1	Spots	<p>A) Clear</p> <table border="1"> <thead> <tr> <th>Size : d mm</th> <th>Acceptable Qty in active area</th> </tr> </thead> <tbody> <tr> <td>$d \leq 0.1$</td> <td>Disregard</td> </tr> <tr> <td>$0.1 < d \leq 0.2$</td> <td>6</td> </tr> <tr> <td>$0.2 < d \leq 0.3$</td> <td>2</td> </tr> <tr> <td>$0.3 < d$</td> <td>0</td> </tr> </tbody> </table> <p>Note : Including pin holes and defective dots which must be within one pixel size.</p> <p>B) Unclear</p> <table border="1"> <thead> <tr> <th>Size : d mm</th> <th>Acceptable Qty in active area</th> </tr> </thead> <tbody> <tr> <td>$d \leq 0.2$</td> <td>Disregard</td> </tr> <tr> <td>$0.2 < d \leq 0.5$</td> <td>6</td> </tr> <tr> <td>$0.5 < d \leq 0.7$</td> <td>2</td> </tr> <tr> <td>$0.7 < d$</td> <td>0</td> </tr> </tbody> </table>	Size : d mm	Acceptable Qty in active area	$d \leq 0.1$	Disregard	$0.1 < d \leq 0.2$	6	$0.2 < d \leq 0.3$	2	$0.3 < d$	0	Size : d mm	Acceptable Qty in active area	$d \leq 0.2$	Disregard	$0.2 < d \leq 0.5$	6	$0.5 < d \leq 0.7$	2	$0.7 < d$	0	Minor
Size : d mm	Acceptable Qty in active area																						
$d \leq 0.1$	Disregard																						
$0.1 < d \leq 0.2$	6																						
$0.2 < d \leq 0.3$	2																						
$0.3 < d$	0																						
Size : d mm	Acceptable Qty in active area																						
$d \leq 0.2$	Disregard																						
$0.2 < d \leq 0.5$	6																						
$0.5 < d \leq 0.7$	2																						
$0.7 < d$	0																						
2	Lines	<p>A) Clear</p> <p>Note : () - Acceptable Qty in active area L - Length (mm) W - Width (mm) ∞ - Disregard</p> <p>B) Unclear</p>	Minor																				

'Clear' = The shade and size are not changed by V_o .

'Unclear' = The shade and size are changed by V_o .

◆ Screen Cosmetic Criteria (Operating) (Continued)

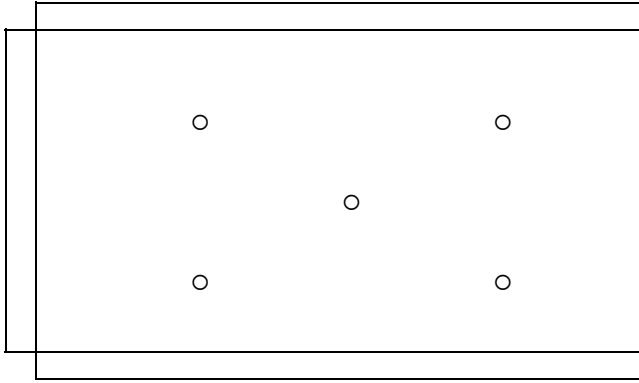
No.	Defect	Judgement Criterion	Partition
3	Rubbing line	Not to be noticeable.	
4	Allowable density	Above defects should be separated more than 10mm each other.	Minor
5	Rainbow	Not to be noticeable.	Minor
6	Dot size	To be 95% ~ 105% of the dot size (Typ.) in drawing. Partial defects of each dot (ex. pin-hole) should be treated as 'spot'. (see <i>Screen Cosmetic Criteria (Operating) No.1</i>)	Minor
7	Uneven brightness (only back-lit type module)	Uneven brightness must be $B_{MAX} / B_{MIN} \leq 2$ - B_{MAX} : Max. value by measure in 5 points - B_{MIN} : Min. value by measure in 5 points Divide active area into 4 vertically and horizontally. Measure 5 points shown in the following figure.  ○ : Measuring points	Minor

Note :

- (1) Size : $d = (\text{long length} + \text{short length}) / 2$
- (2) The limit samples for each item have priority.
- (3) Complexed defects are defined item by item, but if the number of defects are defined in above table, the total number should not exceed 10.
- (4) In case of 'concentration', even the spots or the lines of 'disregarded' size should not allowed. Following three situations should be treated as 'concentration'.
 - 7 or over defects in circle of $\varnothing 5\text{mm}$.
 - 10 or over defects in circle of $\varnothing 10\text{mm}$.
 - 20 or over defects in circle of $\varnothing 20\text{mm}$.

■ PRECAUTIONS FOR USING LCD MODULES

◆ Handing Precautions

- (1) The display panel is made of glass. Do not subject it to a mechanical shock by dropping it or impact.
- (2) If the display panel is damaged and the liquid crystal substance leaks out, be sure not to get any in your mouth. If the substance contacts your skin or clothes, wash it off using soap and water.
- (3) Do not apply excessive force to the display surface or the adjoining areas since this may cause the color tone to vary.
- (4) The polarizer covering the display surface of the LCD module is soft and easily scratched. Handle this polarizer carefully.
- (5) If the display surface becomes contaminated, breathe on the surface and gently wipe it with a soft dry cloth. If it is heavily contaminated, moisten cloth with one of the following solvents :
 - Isopropyl alcohol
 - Ethyl alcohol
- (6) Solvents other than those above-mentioned may damage the polarizer. Especially, do not use the following.
 - Water
 - Ketone
 - Aromatic solvents
- (7) Exercise care to minimize corrosion of the electrode. Corrosion of the electrodes is accelerated by water droplets, moisture condensation or a current flow in a high-humidity environment.

(8) Install the LCD Module by using the mounting holes. When mounting the LCD module make sure it is free of twisting, warping and distortion. In particular, do not forcibly pull or bend the I/O cable or the backlight cable.

(9) Do not attempt to disassemble or process the LCD module.

(10) NC terminal should be open. Do not connect anything.

(11) If the logic circuit power is off, do not apply the input signals.

(12) To prevent destruction of the elements by static electricity, be careful to maintain an optimum work environment.

- Be sure to ground the body when handling the LCD modules.

- Tools required for assembling, such as soldering irons, must be properly grounded.

- To reduce the amount of static electricity generated, do not conduct assembling and other work under dry conditions.

- The LCD module is coated with a film to protect the display surface. Exercise care when peeling off this protective film since static electricity may be generated.

◆ Storage Precautions

When storing the LCD modules, avoid exposure to direct sunlight or to the light of fluorescent lamps. Keep the modules in bags (avoid high temperature / high humidity and low temperatures below 0°C). Whenever possible, the LCD modules should be stored in the same conditions in which they were shipped from our company.

◆ Others

Liquid crystals solidify under low temperature (below the storage temperature range) leading to defective orientation or the generation of air bubbles (black or white). Air bubbles may also be generated if the module is subject to a low temperature.

If the LCD modules have been operating for a long time showing the same display patterns, the display patterns may remain on the screen as ghost images and a slight contrast irregularity may also appear. A normal operating status can be regained by suspending use for some time. It should be noted that this phenomenon does not adversely affect performance reliability.

To minimize the performance degradation of the LCD modules resulting from destruction caused by static electricity etc., exercise care to avoid holding the following sections when handling the modules.

- Exposed area of the printed circuit board.

- Terminal electrode sections.

■ USING LCD MODULES

◆ Liquid Crystal Display Modules

LCD is composed of glass and polarizer. Pay attention to the following items when handling.

(1) Please keep the temperature within specified range for use and storage. Polarization degradation, bubble generation or polarizer peel-off may occur with high temperature and high humidity.

(2) Do not touch, push or rub the exposed polarizers with anything harder than an HB pencil lead (glass, tweezers, etc.).

(3) N-hexane is recommended for cleaning the adhesives used to attach front/rear polarizers and reflectors made of organic substances which will be damaged by chemicals such as acetone, toluene, ethanol and isopropylalcohol.

(4) When the display surface becomes dusty, wipe gently with absorbent cotton or other soft material like chamois soaked in petroleum benzin. Do not scrub hard to avoid damaging the display surface.

(5) Wipe off saliva or water drops immediately, contact with water over a long period of time may cause deformation or color fading.

(6) Avoid contacting oil and fats.

(7) Condensation on the surface and contact with terminals due to cold will damage, stain or dirty the polarizers. After products are tested at low temperature they must be warmed up in a container before coming in contact with room temperature air.

(8) Do not put or attach anything on the display area to avoid leaving marks on.

(9) Do not touch the display with bare hands. This will stain the display area and degrade insulation between terminals (some cosmetics are determined to the polarizers).

(10) As glass is fragile. It tends to become or chipped during handling especially on the edges. Please avoid dropping or jarring.

◆ Installing LCD Modules

The hole in the printed circuit board is used to fix LCM as shown in the picture below. Attend to the following items when installing the LCM.

- (1) Cover the surface with a transparent protective plate to protect the polarizer and LC cell.

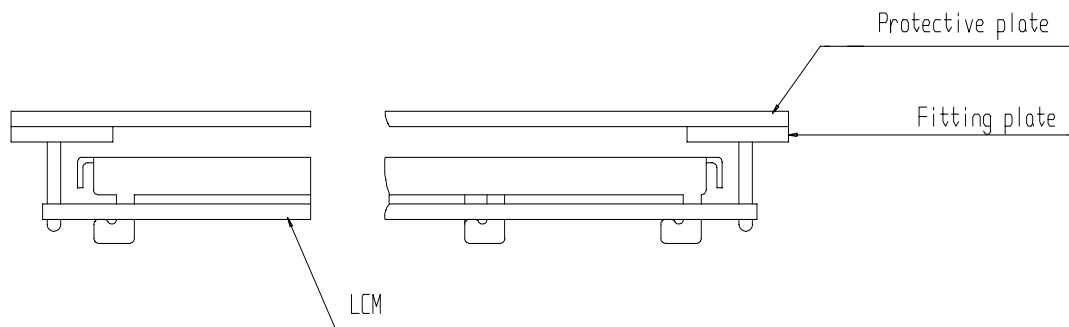

- (2) When assembling the LCM into other equipment, the spacer to the bit between the LCM and the fitting plate should have enough height to avoid causing stress to the module surface, refer to the individual specifications for measurements. The measurement tolerance should be $\pm 0.1\text{mm}$.

◆ Precaution for Handling LCD Modules

Since LCM has been assembled and adjusted with a high degree of precision, avoid applying excessive shocks to the module or making any alterations or modifications to it.

- (1) Do not alter, modify or change the the shape of the tab on the metal frame.
- (2) Do not make extra holes on the printed circuit board, modify its shape or change the positions of components to be attached.
- (3) Do not damage or modify the pattern writing on the printed circuit board.
- (4) Absolutely do not modify the zebra rubber strip (conductive rubber) or heat seal connector.
- (5) Except for soldering the interface, do not make any alterations or modifications with a soldering iron.
- (6) Do not drop, bend or twist LCM.

◆ Electro-Static Discharge Control

Since this module uses a CMOS LSI, the same careful attention should be paid to electrostatic discharge as for an ordinary CMOS IC.

- (1) Make certain that you are grounded when handling LCM.
- (2) Before remove LCM from its packing case or incorporating it into a set, be sure the module and your body have the same electric potential.
- (3) When soldering the terminal of LCM, make certain the AC power source for the soldering iron does not leak.
- (4) When using an electric screwdriver to attach LCM, the screwdriver should be of ground potentiality to minimize as much as possible any transmission of electromagnetic waves produced sparks coming from the commutator of the motor.
- (5) As far as possible make the electric potential of your work clothes and that of the work bench the ground potential.
- (6) To reduce the generation of static electricity be careful that the air in the work is not too dried. A relative humidity of 50%-60% is recommended.

◆ Precaution for soldering to the LCM

- (1) Observe the following when soldering lead wire, connector cable and etc. to the LCM.
 - Soldering iron temperature : $280^{\circ}\text{C} \pm 10^{\circ}\text{C}$.
 - Soldering time : 3-4 sec.
 - Solder : eutectic solder.

If soldering flux is used, be sure to remove any remaining flux after finishing to soldering operation. (This does not apply in the case of a non-halogen type of flux.) It is recommended that you protect the LCD surface with a cover during soldering to prevent any damage dur to flux spatters.

- (2) When soldering the electroluminescent panel and PC board, the panel and board should not be detached more than three times. This maximum number is determined by the temperature and time conditions mentioned above, though there may be some variance depending on the temperature of the soldering iron.

- (3) When remove the electoluminescent panel from the PC board, be sure the solder has completely melted, the soldered pad on the PC board could be damaged.

◆ Precautions for Operation

- (1) Viewing angle varies with the change of liquid crystal driving voltage (V_0). Adjust V_0 to show the best contrast.
- (2) Driving the LCD in the voltage above the limit shortens its life.
- (3) Response time is greatly delayed at temperature below the operating temperature range. However, this does not mean the LCD will be out of the order. It will recover when it returns to the specified temperature range.
- (4) If the display area is pushed hard during operation, the display will become abnormal. However, it will return to normal if it is turned off and then back on.
- (5) Condensation on terminals can cause an electrochemical reaction disrupting the terminal circuit. Therefore, it must be used under the relative condition of 40°C , 50% RH.
- (6) When turning the power on, input each signal after the positive/negative voltage becomes stable.

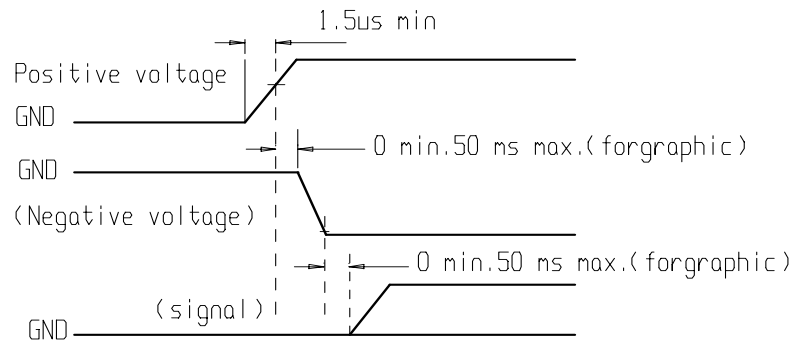

◆ Storage

When storing LCDs as spares for some years, the following precaution are necessary.

- (1) Store them in a sealed polyethylene bag. If properly sealed, there is no need for dessicant.
- (2) Store them in a dark place. Do not expose to sunlight or fluorescent light, keep the temperature between 0°C and 35°C.
- (3) The polarizer surface should not come in contact with any other objects. (We advise you to store them in the container in which they were shipped.)
- (4) Environmental conditions :
 - Do not leave them for more than 168hrs. at 60°C.
 - Should not be left for more than 48hrs. at -20°C.

◆ Safety

- (1) It is recommended to crush damaged or unnecessary LCDs into pieces and wash them off with solvents such as acetone and ethanol, which should later be burned.
- (2) If any liquid leaks out of a damaged glass cell and comes in contact with the hands, wash off thoroughly with soap and water.

◆ Limited Warranty

Unless agreed between SUNSON and customer, SUNSON will replace or repair any of its LCD modules which are found to be functionally defective when inspected in accordance with SUNSON LCD acceptance standards (copies available upon request) for a period of one year from date of shipments. Cosmetic/visual defects must be returned to SUNSON within 90 days of shipment. Confirmation of such date shall be based on freight documents. The warranty liability of SUNSON limited to repair and/or replacement on the terms set forth above. SUNSON will not be responsible for any subsequent or consequential events.

◆ Return LCM under warranty

No warranty can be granted if the precautions stated above have been disregarded. The typical examples of violations are :

- Broken LCD glass.
- PCB eyelet's damaged or modified.
- PCB conductors damaged.
- Circuit modified in any way, including addition of components.
- PCB tampered with by grinding, engraving or painting varnish.
- soldering to or modifying the bezel in any manner.

Module repairs will be invoiced to the customer upon mutual agreement. Modules must be returned with sufficient description of the failures or defects. Any connectors or cable installed by the customer must be removed completely without damaging the PCB eyelet's, conductors and terminals.